



# TDA7332

## RDS FILTER

- HIGH PERFORMANCE, STABLE 57KHz FILTER
- HIGH SELECTIVITY
- FLAT GROUP DELAY
- HIGH PERFORMANCE LIMITER
- VERY FEW EXTERNAL COMPONENTS
- 4.332MHz CLOCK OSCILLATOR (8.664MHz OPTIONAL)

### DESCRIPTION

The TDA7332 is an RDS filter, realized in switched capacitor technique.

The 4 biquad stage architecture is working with 4.332MHz clock.

Optionally a 8.664MHz xtal can be used.

The filter has a center frequency of 57KHz and a bandwidth of 3KHz. Input 2<sup>nd</sup> order antialiasing filter and output smoothing filter are provided.

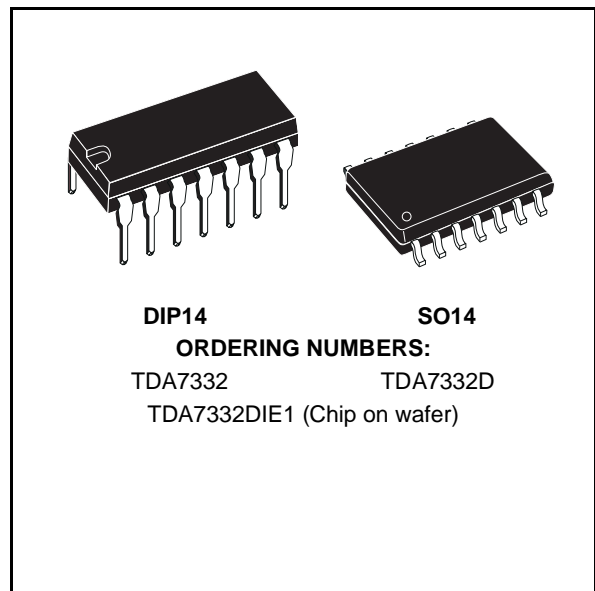

### TEST CIRCUIT

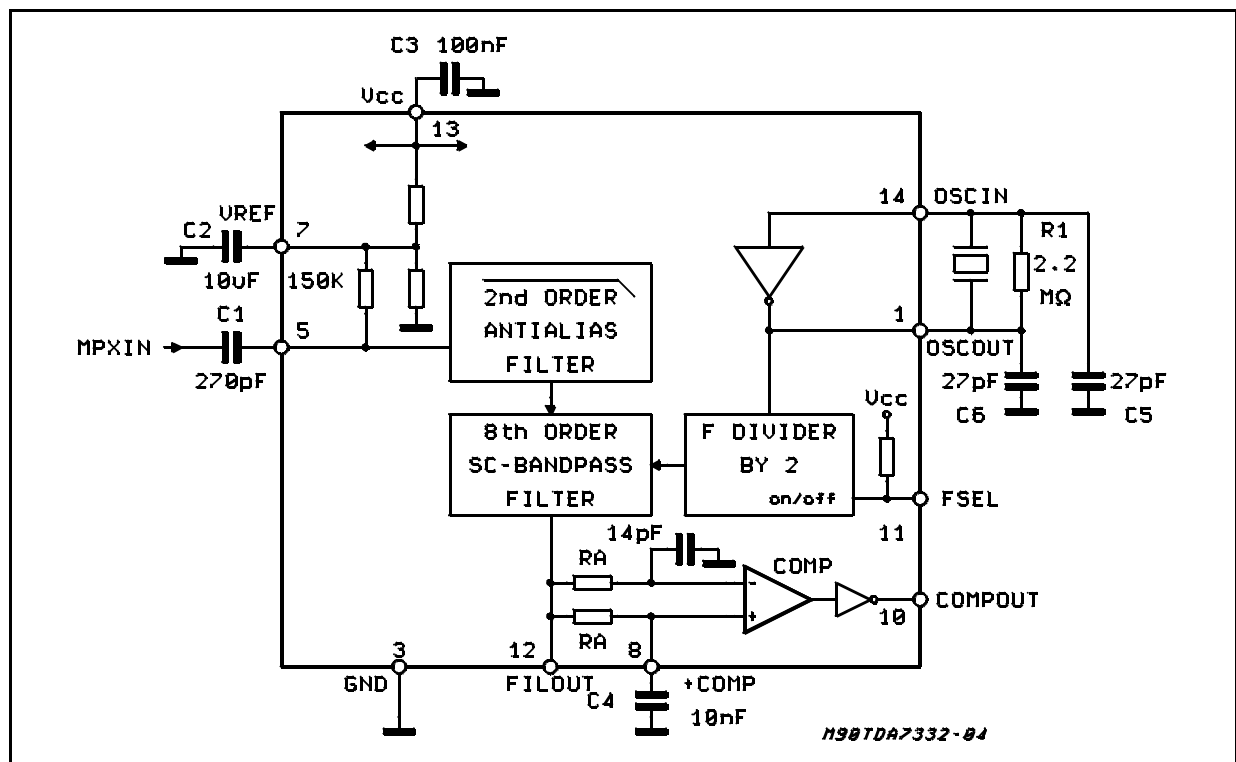

# TDA7332

## ABSOLUTE MAXIMUM RATINGS

Symbol	Parameter	Value	Unit
$V_S$	Supply Voltage	7	V
$T_{op}$	Operating Temperature Range	-40 to 85	°C
$T_{stg}$	Storage Temperature	-40 to 150	°C

## THERMAL DATA

Symbol	Description	DIP14	SO14	Unit
$R_{th\ j-case}$	Thermal Resistance Junction-case	Typ. 100	200	°C/W

## PIN CONNECTION (Top view)

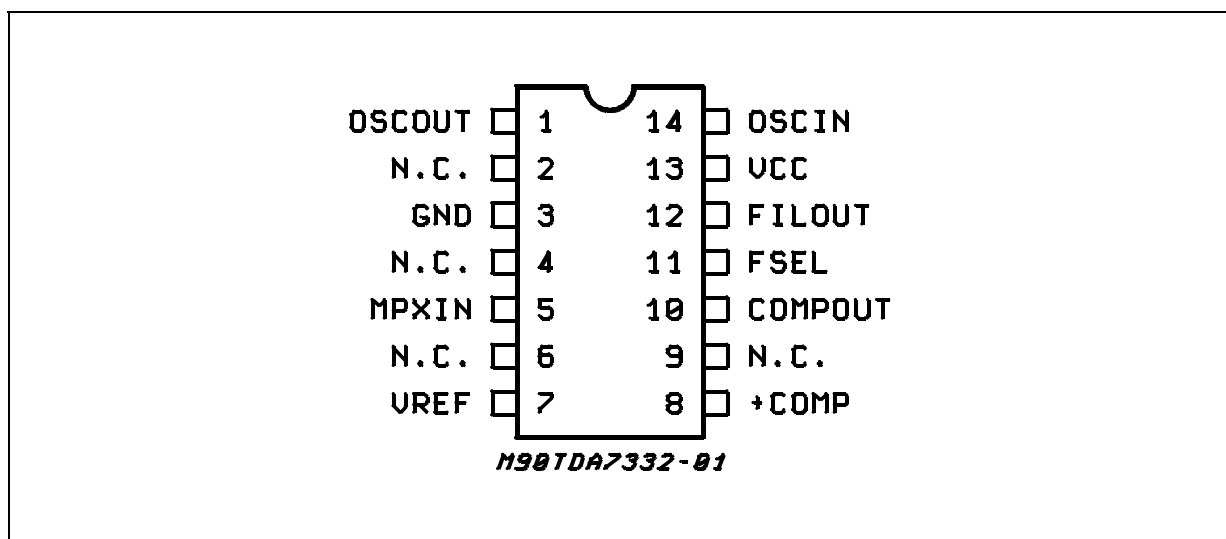

## BONDING PAD LOCATIONS (Top view)

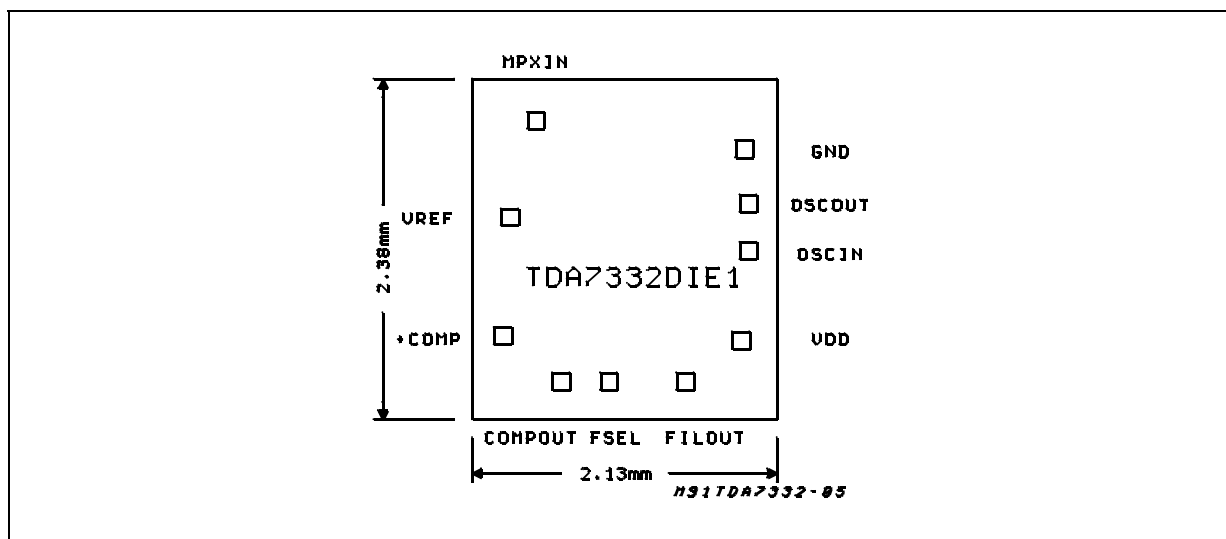

**ELECTRICAL CHARACTERISTICS** ( $V_{CC} = 5V$ ,  $T_{amb} = 25^{\circ}C$ ;  $f_{osc} = 4.332MHz$ ;  $V_{IN} = 20mV_{rms}$  unless otherwise specified)

Symbol	Parameter	Test Condition	Min.	Typ.	Max.	Unit
--------	-----------	----------------	------	------	------	------

## SUPPLY SECTION

$V_{CC}$	Supply Voltage		4.5	5	5.5	V
$I_S$	Supply Current		6	9	14	mA

## FILTER

$F_C$	Center Frequency		56.5	57	57.5	KHz
BW	3dB Bandwidth		2.5	3	3.5	KHz
G	Gain	$f = 57KHz$	18	20	22	dB
A	Attenuation	$\Delta f = \pm 4KHz$ $f = 38KHz$ ; $V_i = 500mV_{rms}$ $f = 67KHz$ ; $V_i = 250mV_{rms}$	18 50 35	22 80 50		dB dB dB
$\Delta Ph$	Phase non linearity	A (see note1) B (see note1) C (see note1)		0.5 1 2	5 7.5 10	DEG DEG DEG
$R_i$	Input Impedance		100	160	200	K $\Omega$
S/N	Signal to Noise Ratio	$V_i = 3mV_{rms}$	30	40		dB
$V_i$	Input Signal	$f = 19KHz$ ; $T_3 \leq -40dB$ (see note2) $f = 57KHz$ (RDS + ARI)			1 50	V $_{rms}$ mV $_{rms}$
$R_L$	Load Impedance	Pin 12	100			K $\Omega$

## LIMITER

RA	Resistance pin 8-12		15	21	28	K $\Omega$
$V_{OL}$	Comp. Output LOW	$I_O = +0.5mA$			1	V
$V_{OH}$	Comp. Output HIGH	$I_O = -0.5mA$	4			V
	Duty Cycle	$V_i = 1mV_{rms}$		50		%

## OSCILLATOR

$F_{OSC}$	Oscillator Frequency	$F_{SEL} = \text{Open}$ $F_{SEL} = \text{Closed to Ground}$		4.332 8.664		MHz MHz
	Output Amplitude			5		V $_{PP}$
$V_{CLL}$	Clock Input Level LOW				1	V
$V_{OLH}$	Clock Input Level HIGH		4			V

CRYSTAL TYPE = EURO QUARTZ

**Note (1):**

The phase non linearity is defined as:  $\Delta Ph = | -2 \phi f_2 + \phi f_1 + \phi f_3 |$   
where  $\phi f_x$  is the input-output phase difference at the frequency  $f_x$  ( $x = 1,2,3$ )

Measure	f1 (KHz)	f2 (KHz)	f3 (KHz)	$\Delta Ph$ max
A	56.5	57	57.5	<5°
B	56	57	58	<7.5°
C	55.5	57	58.5	<10°

**Note (2):** The 3th harmonic (57KHz) at the output (pin12) must be less than -40dB in respect to the input signal plus gain.

DIM.	mm			inch		
	MIN..	TYP.	MAX..	MIN..	TYP..	MAX..
A			1.75			0.069
a1	0.1		0.25	0.004		0.009
a2			1.6			0.063
b	0.35		0.46	0.014		0.018
b1	0.19		0.25	0.007		0.010
C		0.5			0.020	
c1	45° (typ.)					
D (1)	8.55		8.75	0.336		0.344
E	5.8		6.2	0.228		0.244
e		1.27			0.050	
e3		7.62			0.300	
F (1)	3.8		4	0.150		0.157
G	4.6		5.3	0.181		0.209
L	0.4		1.27	0.016		0.050
M			0.68			0.027
S	8° (max)					

**OUTLINE AND MECHANICAL DATA**

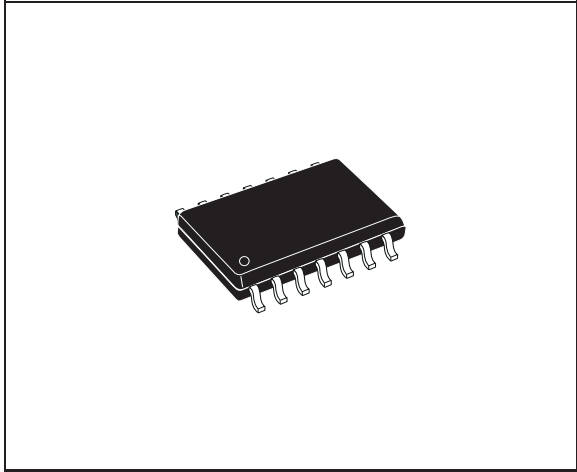

**SO14**

(1) D and F do not include mold flash or protrusions. Mold flash or protrusions shall not exceed 0.15mm (.006inch).

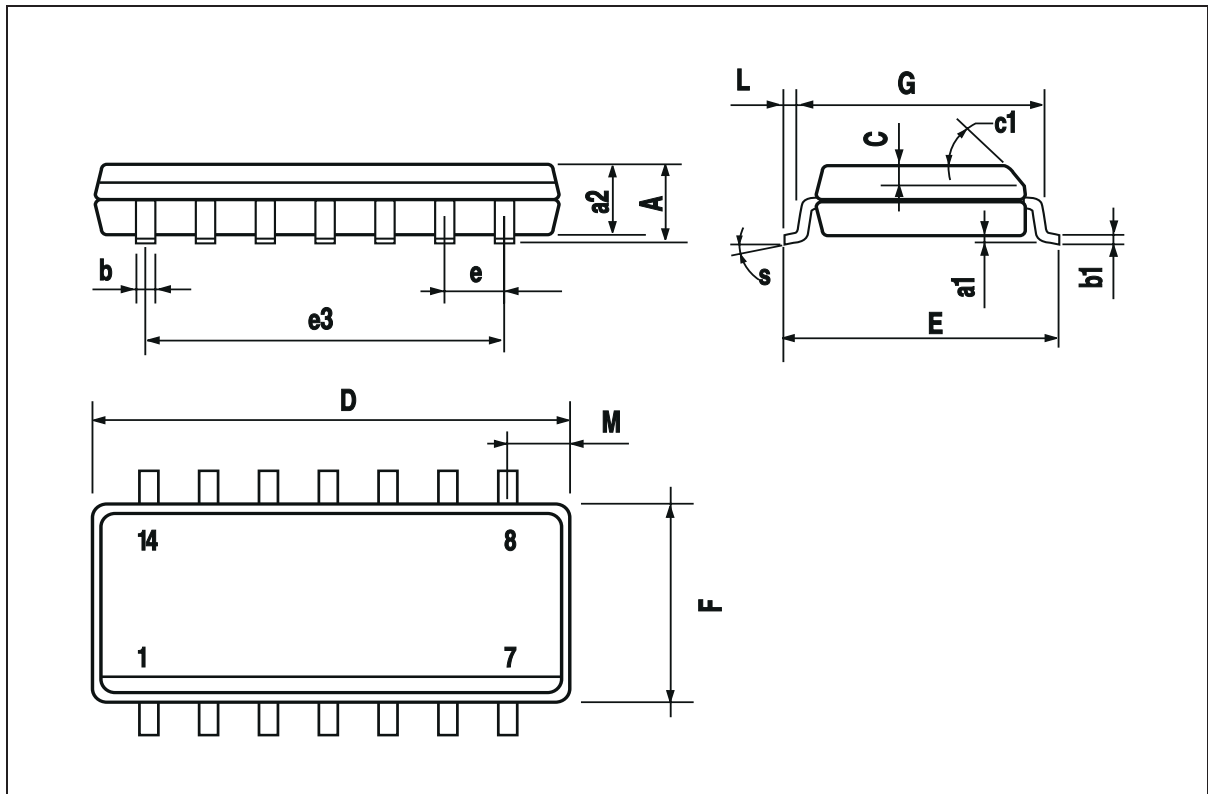

DIM.	mm			inch		
	MIN.	TYP.	MAX.	MIN.	TYP.	MAX.
a1	0.51			0.020		
B	1.39		1.65	0.055		0.065
b		0.5			0.020	
b1		0.25			0.010	
D			20			0.787
E		8.5			0.335	
e		2.54			0.100	
e3		15.24			0.600	
F			7.1			0.280
I			5.1			0.201
L		3.3			0.130	
Z	1.27		2.54	0.050		0.100

**OUTLINE AND MECHANICAL DATA**

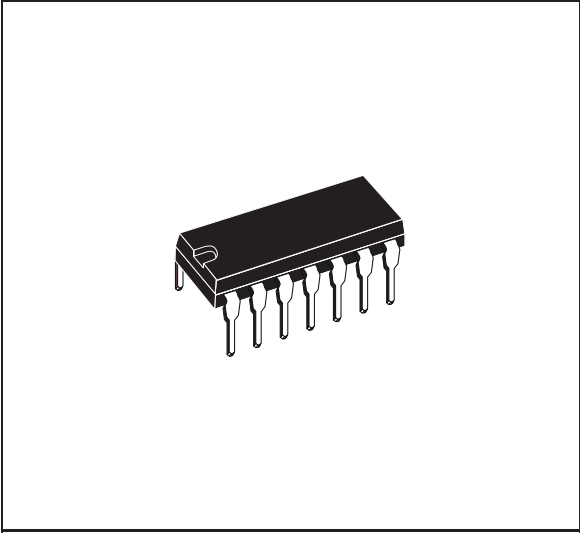

**DIP14**

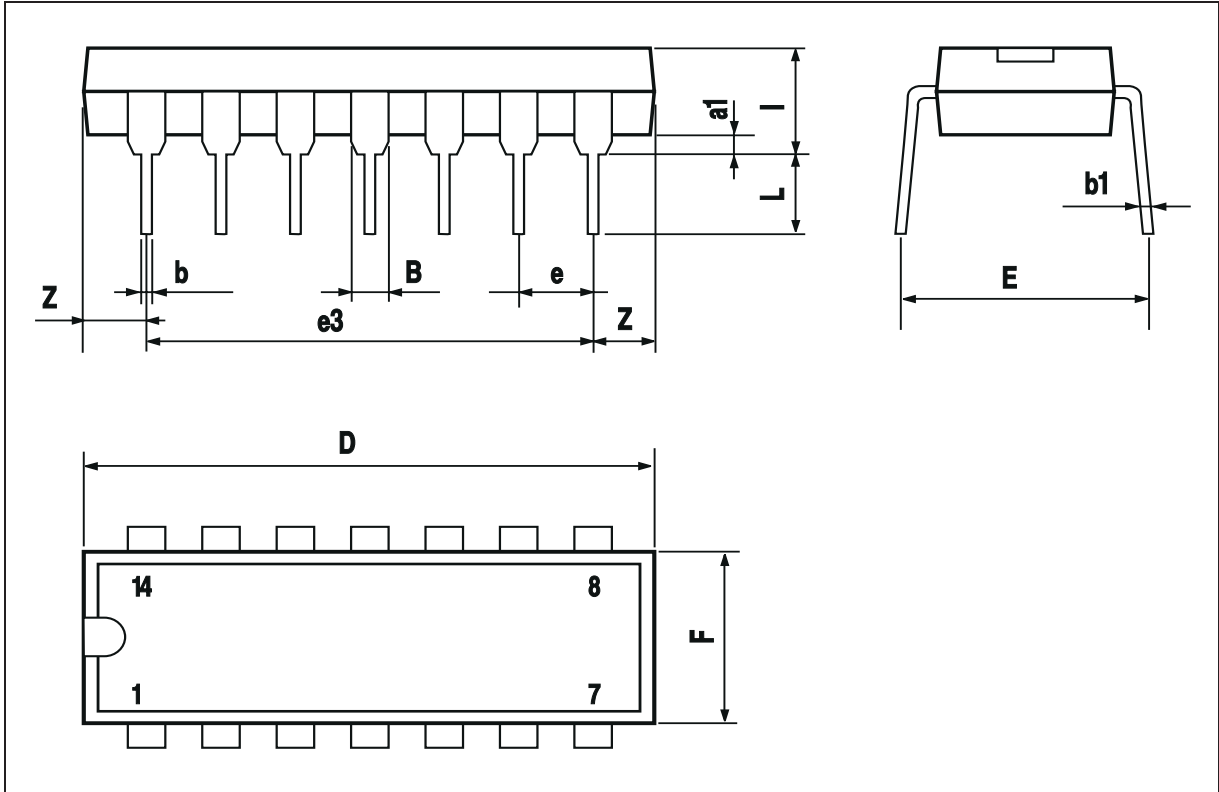

Information furnished is believed to be accurate and reliable. However, STMicroelectronics assumes no responsibility for the consequences of use of such information nor for any infringement of patents or other rights of third parties which may result from its use. No license is granted by implication or otherwise under any patent or patent rights of STMicroelectronics. Specification mentioned in this publication are subject to change without notice. This publication supersedes and replaces all information previously supplied. STMicroelectronics products are not authorized for use as critical components in life support devices or systems without express written approval of STMicroelectronics.

The ST logo is a registered trademark of STMicroelectronics

© 1999 STMicroelectronics – Printed in Italy – All Rights Reserved

STMicroelectronics GROUP OF COMPANIES

Australia - Brazil - China - Finland - France - Germany - Hong Kong - India - Italy - Japan - Malaysia - Malta - Morocco -  
Singapore - Spain - Sweden - Switzerland - United Kingdom - U.S.A.

<http://www.st.com>